

OptiMat E Range of molded case circuit breakers



OptiMat E molded case circuit breaker series is represented by reliable and simple protection devices designed for low-voltage distribution systems, current conducting in normal mode and current blocking during short circuits, overloads and up to 30 operative activations and deactivations of electric circuits per day. Circuit breakers approved by the Russian Maritime Register of Shipping (hereinafter RS) and the Russian River Register (hereinafter RRR) are designed to protect electrical equipment on ships and port infrastructure.

Designation

OptiMat E 100 L 100 UHL3



1	Product range	OptiMat		
2	Configuration	E - molded case circuit breakers		
3	Rated current I_n , A	100	250	
4	Limiting breaking capacity, kA	L - 15 ¹⁾ N - 20 ²⁾	L - 18 N - 25 H - 40	
5	Thermomagnetic release rated current, A	16, 20, 25, 32, 40, 50, 63, 80, 100	125, 160, 200, 250	
6	Symbol of environment and environmental class of location	UHL3 (international TC3) - QCD (quality control department) acceptance	UHL3-REG (international TC3) - RRR acceptance	OM4-REG (international UM4) - RS acceptance

¹⁾ Breakers for rated current: 16, 20 A – 6 kA; 25 A – 8 kA.

²⁾ Breakers for rated current: 16...25 A – not available; 32 A – 15 kA.

Basic OptiMat E configuration includes:

- interphase barriers (2 pieces);
- attaching screws kit.

Articles indicated in the tables can be amended. If you did not find the necessary articles on the website, please call KEAZ customer service.

Batch effectiveness



The optimum protection from short circuit conditions and overloads is highly effective with only two machines. Optimal level of maximum switching capacity, 10 to 40 kA, is used on most facilities.



The educational service for consumers increases the effective use of KEAZ Optima equipment. Tech support considering design and exploitation is provided.

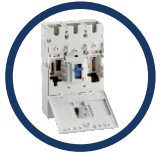

The optimum set of auxiliary accessories expands functional use and facilitates exploitation of the electrical device.



The location in the central part of Russia and domestic manufacture allows to fulfill equipment delivery as soon as possible.



Warranty 5 years. Each unit undergoes multi-stage quality control from assembling to the finished goods warehouse.



OptiMat E automatic breakers can be used within the temperature rate -60 ...+40 C.



The use of modern materials: silver-containing contacts decrease transition resistance, increase resistance towards boiling and have high wear resistance. Plastic do not sustain combustion, has high insulation properties and arc resistance.



It's possible to install the breaker in any position, with the supply lead either from above or from under, without damaging technical characteristics of the breaker.

Reference (series)

Appearance	Rated current In, A	Nomenclature (general purpose industrial design)	References	Nomenclature (RS acceptance design)	References	Nomenclature (RRR acceptance design)	References	Масса, кг
	16...100	OptiMat E100L016-UHL3	100000	OptiMat E100L016-OM4-REG	273882	OptiMat E100L016-UHL3-REG	273883	0,8
		OptiMat E100L020-UHL3	100001	OptiMat E100L020-OM4-REG	273884	OptiMat E100L020-UHL3-REG	273885	
		OptiMat E100L025-UHL3	100002	OptiMat E100L025-OM4-REG	273886	OptiMat E100L025-UHL3-REG	273887	
		OptiMat E100L032-UHL3	100003	OptiMat E100L032-OM4-REG	273888	OptiMat E100L032-UHL3-REG	273889	
		OptiMat E100L040-UHL3	100004	OptiMat E100L040-OM4-REG	273890	OptiMat E100L040-UHL3-REG	273891	
		OptiMat E100L050-UHL3	100005	OptiMat E100L050-OM4-REG	273892	OptiMat E100L050-UHL3-REG	273893	
		OptiMat E100L063-UHL3	100006	OptiMat E100L063-OM4-REG	273894	OptiMat E100L063-UHL3-REG	273895	
		OptiMat E100L080-UHL3	100007	OptiMat E100L080-OM4-REG	273896	OptiMat E100L080-UHL3-REG	273897	
		OptiMat E100L100-UHL3	100008	OptiMat E100L100-OM4-REG	273898	OptiMat E100L100-UHL3-REG	273899	
		OptiMat E100N032-UHL3	224958	OptiMat E100N032-OM4-REG	273900	OptiMat E100N032-UHL3-REG	273901	
		OptiMat E100N040-UHL3	224959	OptiMat E100N040-OM4-REG	273902	OptiMat E100N040-UHL3-REG	273903	
		OptiMat E100N050-UHL3	224960	OptiMat E100N050-OM4-REG	273904	OptiMat E100N050-UHL3-REG	273905	
		OptiMat E100N063-UHL3	224961	OptiMat E100N063-OM4-REG	273906	OptiMat E100N063-UHL3-REG	273907	
		OptiMat E100N080-UHL3	224962	OptiMat E100N080-OM4-REG	273908	OptiMat E100N080-UHL3-REG	273909	
		OptiMat E100N100-UHL3	224963	OptiMat E100N100-OM4-REG	273910	OptiMat E100N100-UHL3-REG	273911	
		OptiMat E250L125-UHL3	100009	OptiMat E250L125-OM4-REG	273913	OptiMat E250L125-UHL3-REG	273914	
OptiMat E250L160-UHL3	100010	OptiMat E250L160-OM4-REG	273915	OptiMat E250L160-UHL3-REG	273916			
OptiMat E250L200-UHL3	100011	OptiMat E250L200-OM4-REG	273917	OptiMat E250L200-UHL3-REG	273918			
OptiMat E250L250-UHL3	100012	OptiMat E250L250-OM4-REG	273919	OptiMat E250L250-UHL3-REG	273920			
OptiMat E250H125-UHL3	230652	OptiMat E250H125-OM4-REG	273921	OptiMat E250H125-UHL3-REG	273922			
OptiMat E250N160-UHL3	230653	OptiMat E250N160-OM4-REG	273923	OptiMat E250N160-UHL3-REG	273924			
OptiMat E250N200-UHL3	230654	OptiMat E250N200-OM4-REG	273925	OptiMat E250N200-UHL3-REG	273926			
OptiMat E250N250-UHL3	230655	OptiMat E250N250-OM4-REG	273927	OptiMat E250N250-UHL3-REG	273928			
OptiMat E250H125-UHL3	230656	OptiMat E250H125-OM4-REG	236194	OptiMat E250H125-UHL3-REG	242899			
OptiMat E250H160-UHL3	230657	OptiMat E250H160-OM4-REG	236195	OptiMat E250H160-UHL3-REG	242900			
OptiMat E250H200-UHL3	230658	OptiMat E250H200-OM4-REG	236196	OptiMat E250H200-UHL3-REG	273929			
OptiMat E250H250-UHL3	230659	OptiMat E250H250-OM4-REG	236197	OptiMat E250H250-UHL3-REG	242902			

Technical specification

Range of automatic breakers		OptiMat E100		OptiMat E250		
Main characteristics						
Rated operating voltage U _e , V		690				
Rated insulation voltage U _i , V		690				
Rated impulse withstand voltage U _{imp} , kV		6				
Application category		A				
Suitability for isolation		available				
Number of poles		3				
Control						
Manual	control lever	+		+		
	standart of rotary extended handle	+		+		
Design						
Fixed with front connection		+		+		
Rated and ultimate parameters of breaker main circuit						
Rated current I _n , A		16, 25, 32, 40, 50, 63, 80, 100			125, 160, 200, 250	
Rated frequency, Hz		50/60				
Levels of breaking capacity		L	N	L	N	H
Rated limiting breaking capacity I _{cu} , kA	U _e 400 V	15 ¹⁾	20 ²⁾	18	25	40
	U _e 690 V	5	5	7,5	10	12
Rated service capacity I _{cs} , % of I _{cu}		50				
Short-circuit making capacity I _{cm} , kA	U _e 400 V	17	40	36	52,5	84
	U _e 690 V	8,5	8,5	13	17	24
General wear resistance, cycles		10000			8000	
Electric wear resistance, cycles		1500			1000	
Protection, indication measurement devices						
Short circuit protection	magnetic tripping value, A	fixed ³⁾			10 I _n	
Overload protection	thermal release value	I _n				
Control and indication complementary attachments						
Auxiliary contacts	left auxiliary contact	+				
	right auxiliary contact	+				
	indication auxiliary contact	+				
	combined auxiliary contact (auxiliary contact+ indication auxiliary contact)	+				
Voltage release	shunt trip	+				
	undervoltage release	+				
Accessories	DIN rail equipment	+				
	interphase barriers	as a set (can be ordered separately)				
	auxiliary terminal shield	+				
	position locking device 'disconnected'	+				
	set of single-connector clasps	+				
Installation and connection						
Connection of copper and aluminium wires and cables with section, mm	I _n ≤ 50 A	2,5 - 10				
	I _n ≥ 63 A	10 - 35				
	125 ≤ I _n ≤ 250 A				35 - 120	
Rigid conductor section connection, mm	I _n ≤ 50 A	2,5 - 16				
	I _n ≥ 63 A	10 - 50				
	125 ≤ I _n ≤ 250 A				35 - 150	
Overall dimensions and weight						
Overall dimensions W*H*D, mm		75x130x60			105x165x60	
Weight, kg		0,8			1,2	

¹⁾ For breakers with rated current: 16, 20 A – 6 kA; 25 A – 8 kA.

²⁾ For breakers with rated current: 16...25 A – is absent; 32 A – 15 kA.

³⁾ For breakers with rated current: 16 A – 350; 20...32 A - 400; 40...100 A - 10 I_n.

Current and time characteristics

OptiMat E100

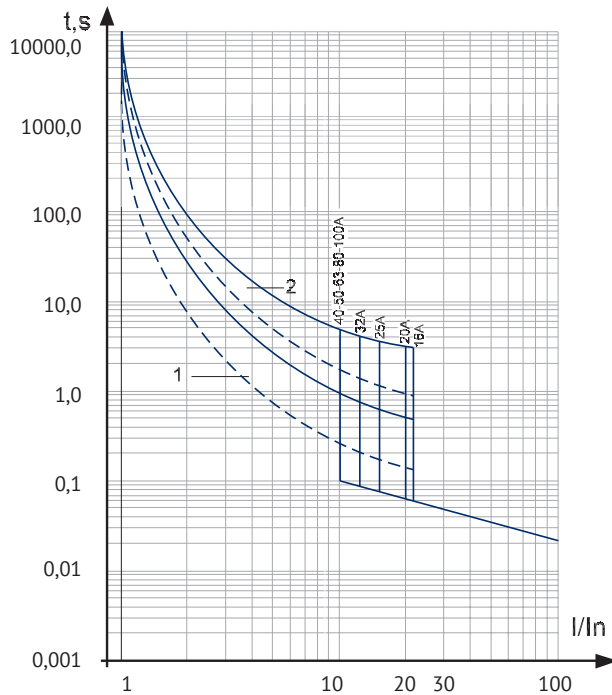

1- working zone of an overcurrent thermal release, from a hot state
2- working zone of an overcurrent thermal release, from a cold state

OptiMat E250

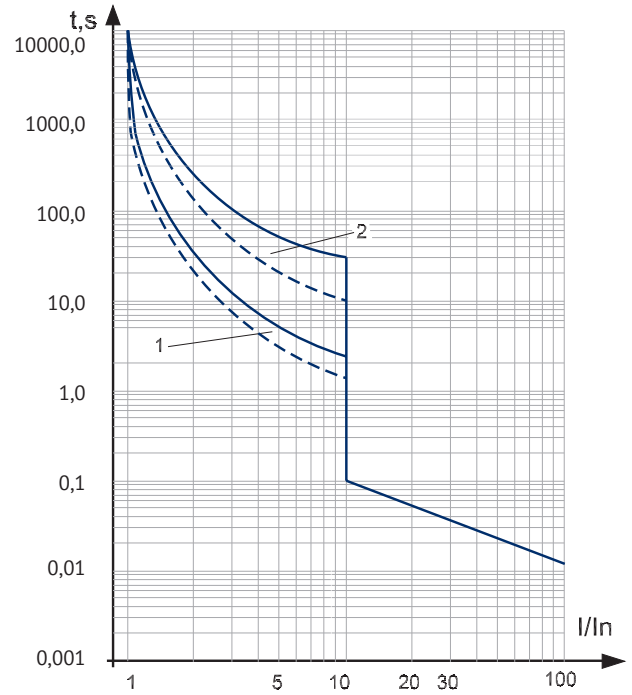

1- working zone of an overcurrent thermal release, from a hot state
2- working zone of an overcurrent thermal release, from a cold state

Rated operating current in accordance with ambient temperature

OptiMat E automatic breakers are equipped with an irregular thermal-magnetic trip unit. At the external temperature of +30 C (+45 C for breakers with RS acceptance) the apparatus have $I=I_n$. The tripping time is defined by a time-current characteristic of the breaker. The dependence of the rated operating current for OptiMat E from the ambient temperature is below.

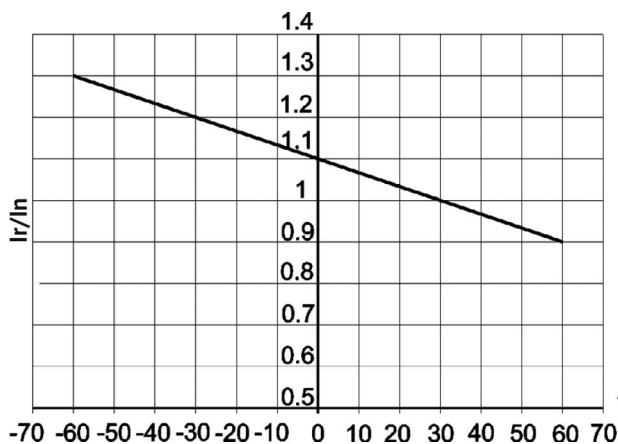

For the breakers of a general purpose industrial design and breakers with RRR acceptance.

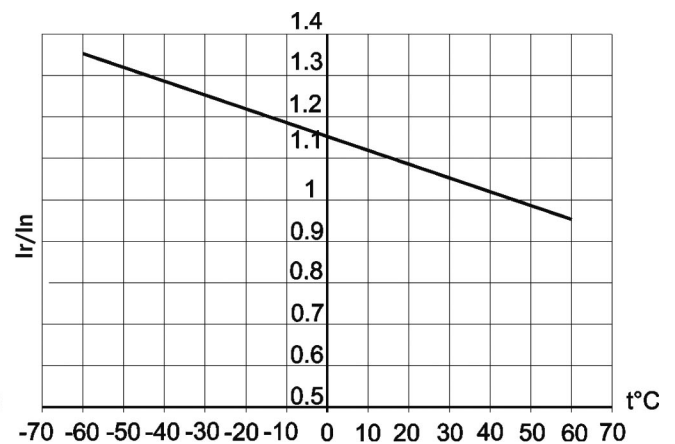

For the breakers with RRR acceptance.

Configuration

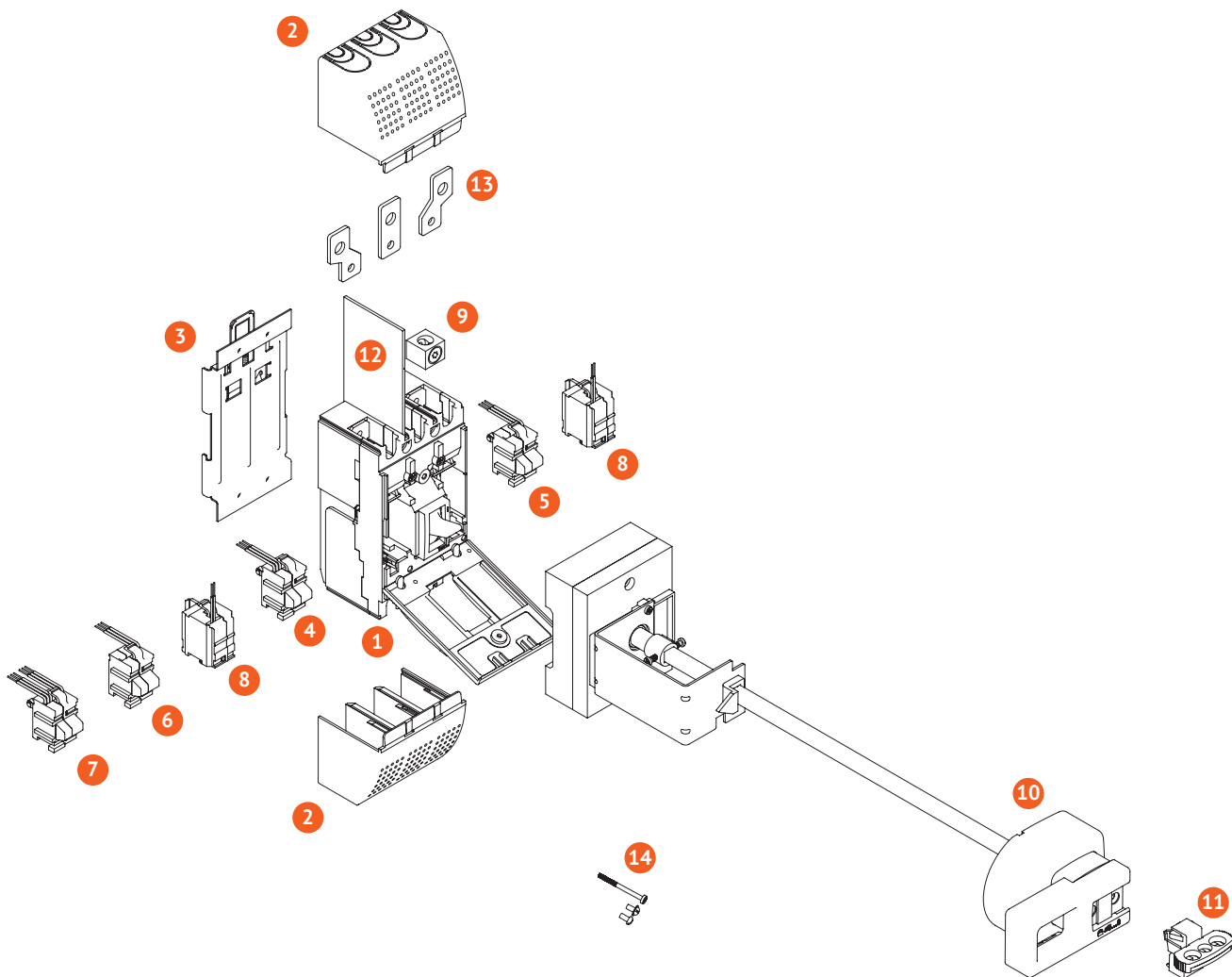

1. Circuit breaker *
2. Terminal covers
3. DIN-rail adapter
4. Auxiliary contact (left)
5. Auxiliary contact (right)
6. Alarm auxiliary contact
7. Combined alarm contact with emergency signal (auxiliary contact + alarm auxiliary contact)
8. Shunt trip
9. Terminal sets for external conductors
10. Locking lever (extended)
11. Position blocking device is «Off»
12. Interpole partitions *
13. Pole extenders
14. Fastening screws set *

* Standard equipment set

Accessories and auxiliary devices

OptiMat E Shunt trip

Shunt trip is designed for circuit breaker remote opening. Unified for OptiMat E100 and OptiMat E250 switches. It is installed under the circuit breaker face panel in its own cell.

Shunt trip causes circuit breaker opening in any operating conditions, when supply voltage remains within the range from 70 to 110 % U_e.

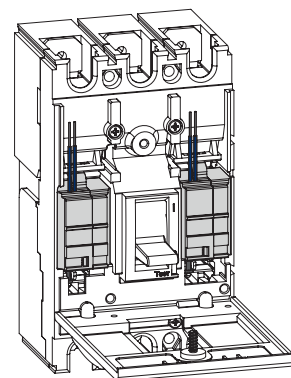

OptiMat E Shunt trip has a built-in contact that removes power from the coil after the independent Shunt trip is triggered.

Operating voltage U_e, V	12AC/DC	24AC/DC	48AC/DC	110AC	230AC	400AC	
Operating voltage range	(0,7-1,1) U _e						
Power consumption, VA	200		400				
Operating mode	short time (pulsed)						
Breaking time, ms	35						
Reference	general purpose industrial version	100031	100032	100033	100034	100035	100036
	RRR acceptance	273960	273964	273968	273958	273962	273966
	RS acceptance	273959	273963	273967	273957	273961	273965



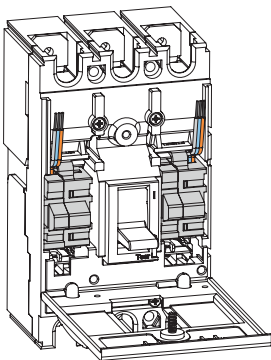
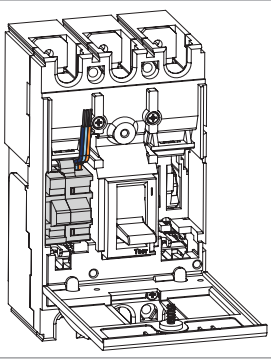
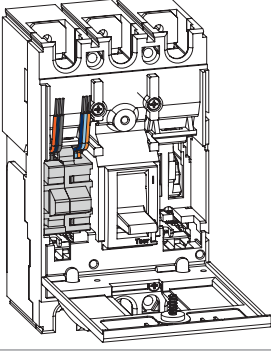

Auxiliary contacts

They are designed to transfer signals about switch operation and used for sending alarms, conduct electric blocking, arrange relay protection, etc. Unified for OptiMat E100 and OptiMat E250 switches. They are installed under the circuit breaker face panel in their own cell.

	Title	Rated operating current (I _r) at the supply voltage, A						Reference		
		(125-250) AC, 50 Гц	30 DC	50 DC	75 DC	125 DC	220 DC	general purpose industrial version	RRR acceptance	RS acceptance
	Left auxiliary contact OptiMat E-UHL3	5	5	1	0,75	0,5	0,25	100018	273944	273943
	Right auxiliary contact OptiMat E-UHL3	5	5	1	0,75	0,5	0,25	100019	273946	273945
	Alarm auxiliary contact OptiMat E-UHL3	5	5	1	0,75	0,5	0,25	100020	273948	273947
	Combined indicating signal OptiMat E-UHL3	5	5	1	0,75	0,5	0,25	100021	273950	273949

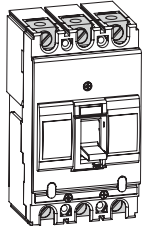
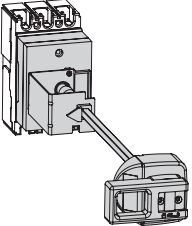
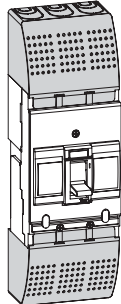
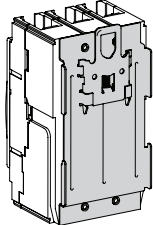
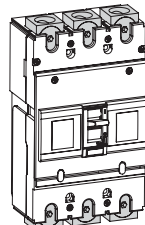
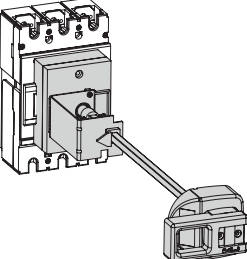
Additional devices for quick and save installation and operation

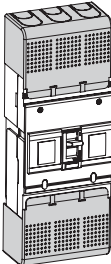
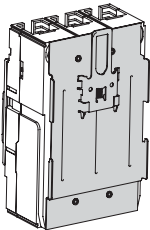
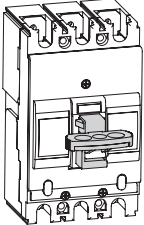
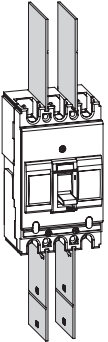
For OptiMat E100	Title	Reference		
		general purpose industrial version	RRR acceptance	RS acceptance
	Clamp kit OptiMat E100-16..50A-UHL3 - 3 pcs.	100015	273938	273937
	Clamp kit OptiMat E100-63..100A-UHL3 - 3 pcs.	100016	273940	273939
	Rotary extended handle OptiMat E100-UHL3	100037	242909	236204
	Terminal cover of OptiMat E100-UHL3 - 2 pcs.	100022	273952	273951
	Din-rail adapter of OptiMat E100-UHL3	100013	273933	273912
Для OptiMat E250				
	Clamp kit OptiMat E250-UHL3 - 3 pcs.	100017	273942	273941
	Rotary extended handle OptiMat E250-UHL3	100039	242910	236205

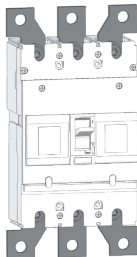
	Наименование	Reference		
		общепром. исполнение	приемка PPP	приемка PC
	Terminal cover of OptiMat E250-UHL3 - 2 pcs.	100023	273954	273953
	Din-rail adapter of OptiMat E250-UHL3	100014	273936	273935
Общие				
	Position blocking device (off) of OptiMat E-UHL3	100041	273970	273969
	Interpole partitions of OptiMat E-UHL3 – 2 pcs.	100024	273956	273955
	Pole extenders of OptiMat E100-16...50-UHL3-3 pcs. Pole extenders of OptiMat E100-63...100-UHL3-3 pcs.	293113 292988		300257 300264
	Pole extenders of OptiMat E250-UHL3 – 3 pcs.	272862	272863	272864

Overall dimensions, mm

OptiMat E100

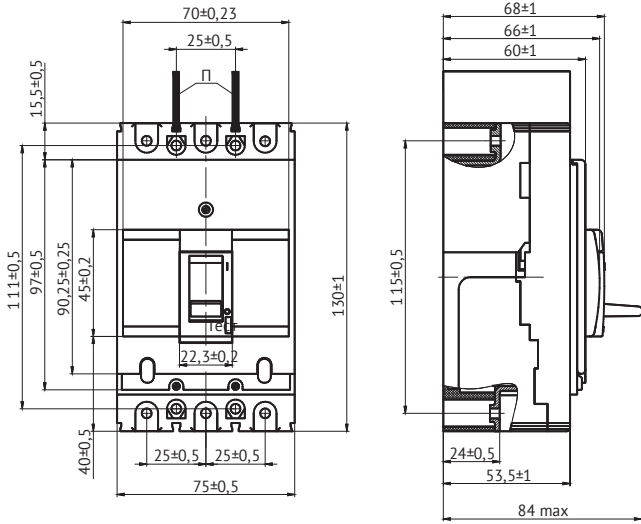

OptiMat E100 with pole extenders

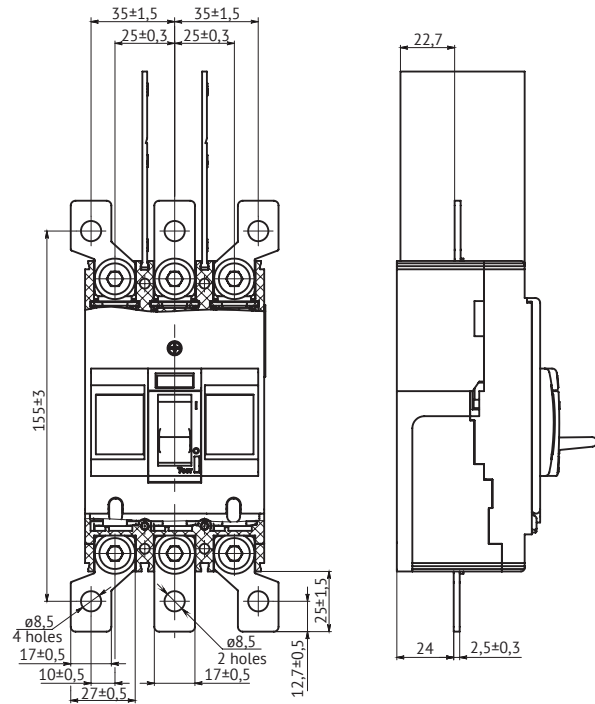

OptiMat E250

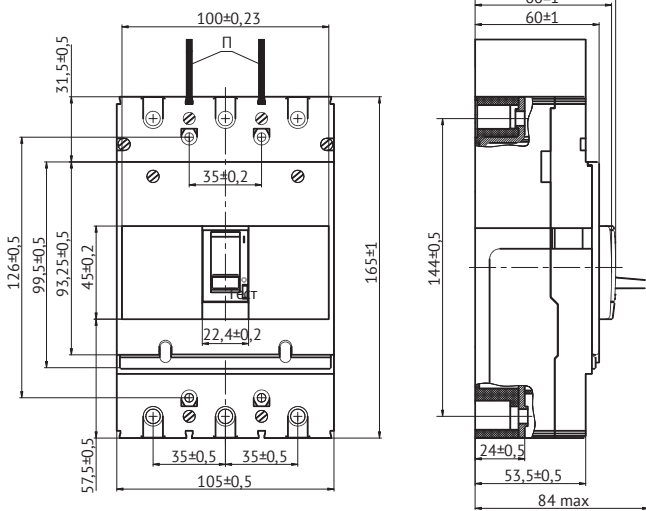

OptiMat E250 with pole extenders

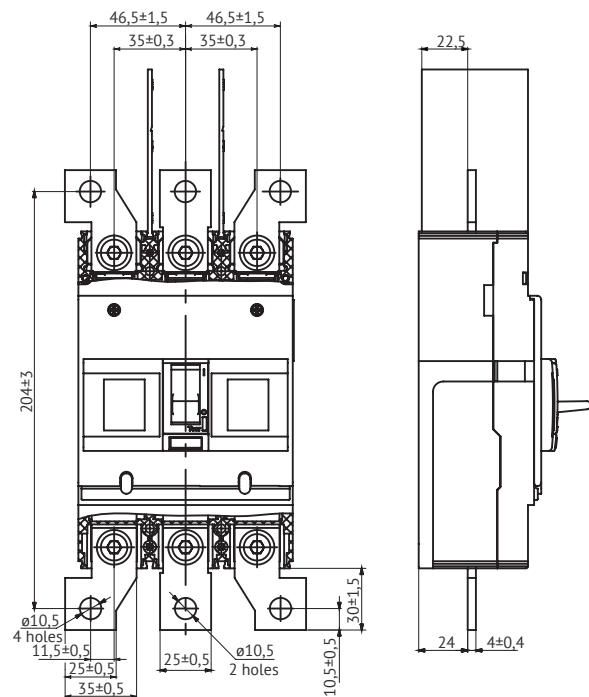

Π - interphase barrier

Models for box marking and drilling

OptiMat E100

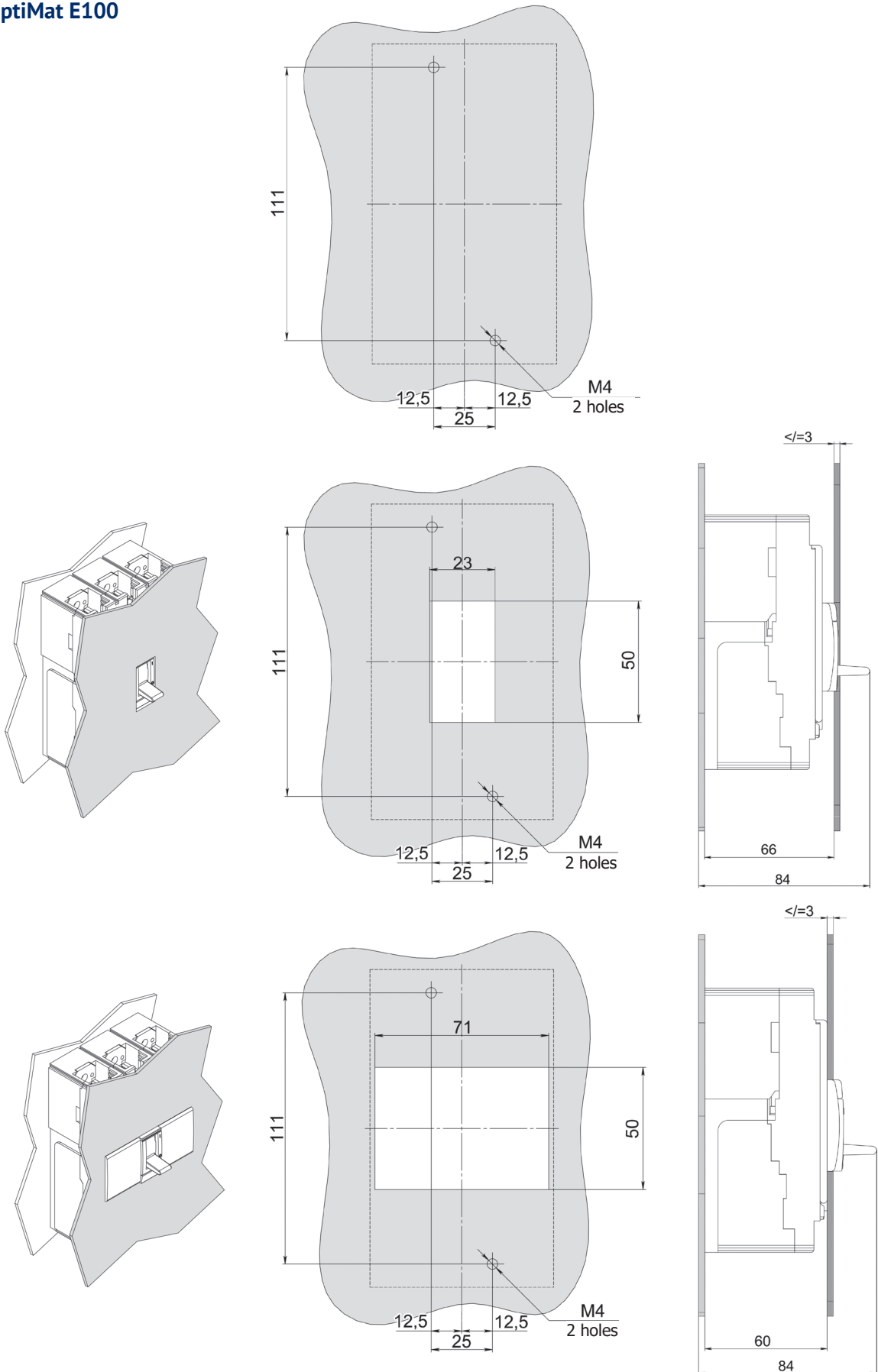

OptiMat E250

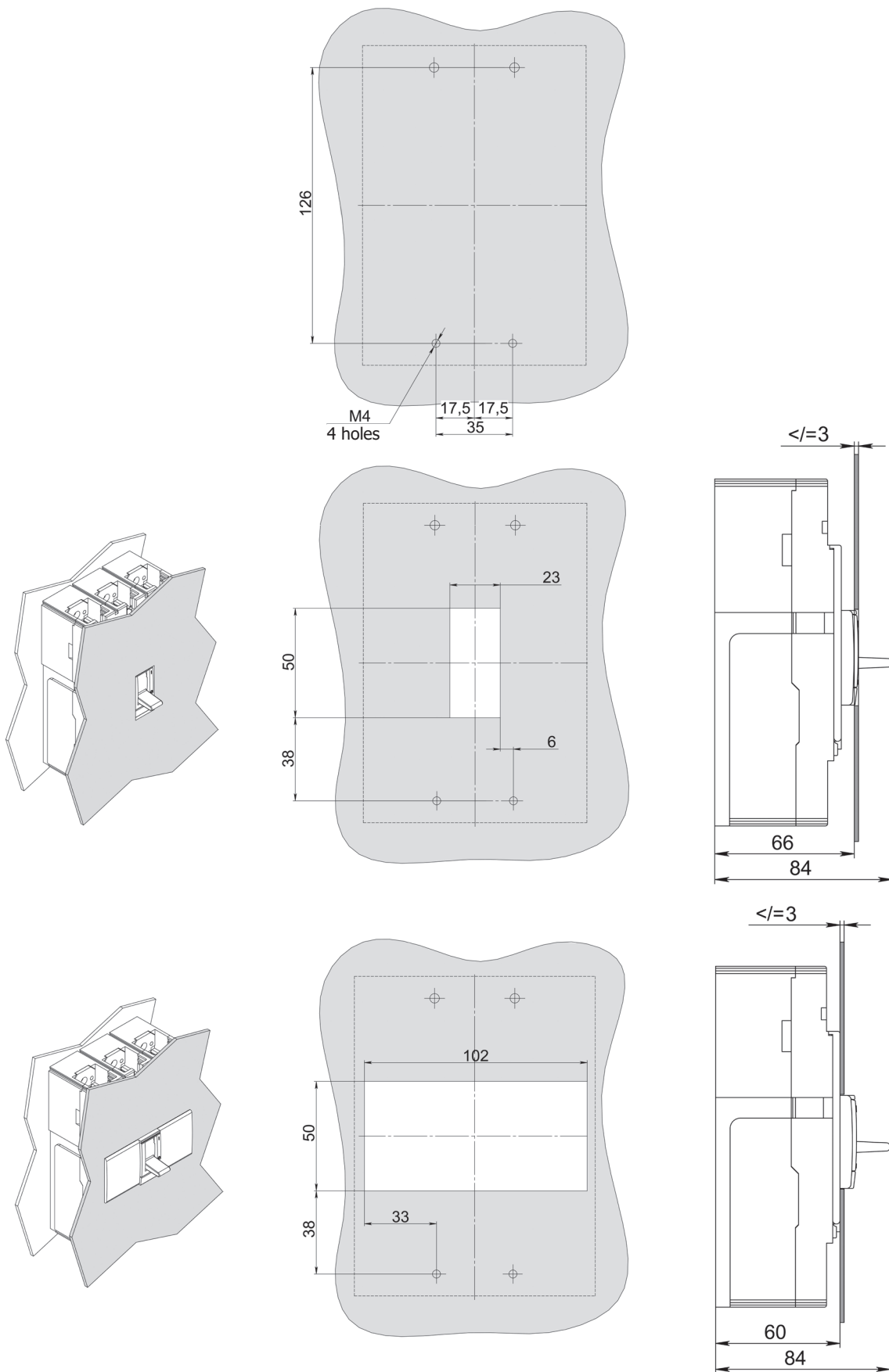

Options for installation of retractable locking lever of OptiMat E100 and E250

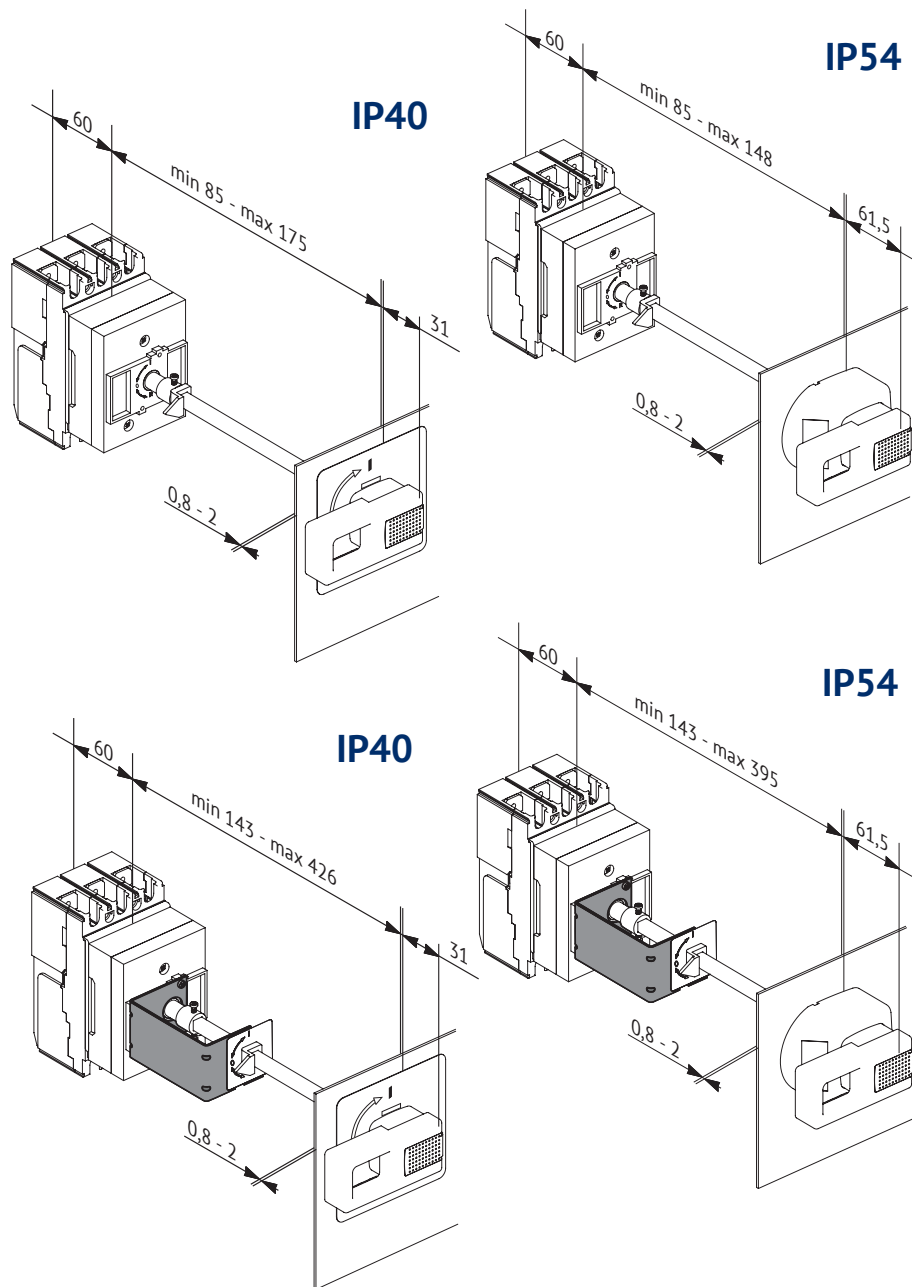

Circuit schematics

Switch without supplementary assembly elements

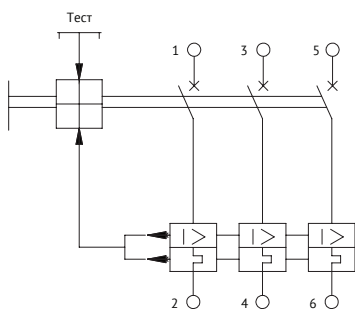

Supplementary assembly elements

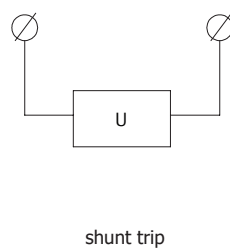

Auxiliary contacts

Auxiliary contacts

14 (yellow)

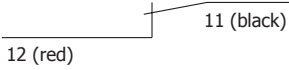

12 (red)

Indication auxiliary contacts

54 (white)



52 (green)

The position of the auxiliary signal contacts and the combined signal contacts is shown for the switch in the "off" position after automatic tripping.

Contact	«Tripped» position	Position «automatic shutdown»	Position «Manual shutdown»
14-11 yellow-black	closed	open	open
12-11 red-black	open	closed	closed
54-51 white-brown	closed	open	closed
52-51 green-brown	open	closed	open

Combined indication signals

14 (yellow)



12 (red)

54 (white)



52 (green)

Ways to attach main circuit conductors of the breaker. Form and size of attaching busbars

Busbar connection or a cable core connection with wiring terminal connector

Cable connection without wiring terminal connector

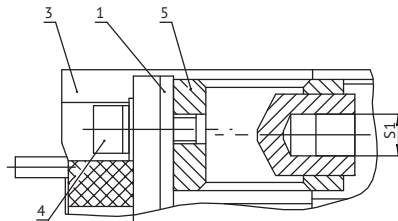
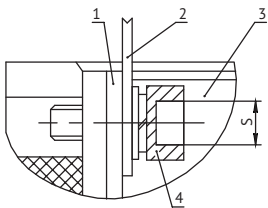

1. Terminal of the breaker
2. Busbar (or wiring terminal connector)
3. Breaker
4. Screwed connection
5. Single connector

Range of products	Rated current	S	S1
OptiMat E100	In = 16...50 A	4	slot
	In = 63...100 A	6	slot
OptiMat E250	In = 100...250 A	6	5

Form and size of the connected switch bus, maximum section

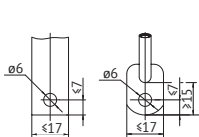

OptiMat E100 16...50A

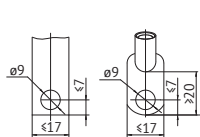

OptiMat E100 63...100A

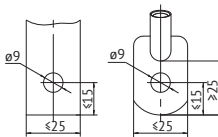

OptiMat E100 with pole extenders

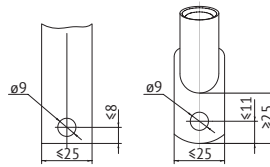

OptiMat E250

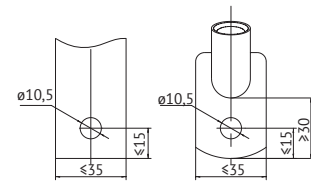

OptiMat E250 with pole extenders

Minimum allowable distance from OptiMat E100 and E250 switches to metal parts of switchgear

